



DEPENDABLE PRODUCTIVITY

NSP10N3
NSP12N2C
NSP12N3
NSP14N3
NSP16N3
NSP12N3I
NSP14N3I
NSP16N3I
NSP10N3R
NSP12N3R
NSP14N3R
NSP16N3R
NSP12N3IR
NSP14N3IR
NSP16N3IR
NSP16N3S
NSP16N3SR

SPECIFICATIONS

PEDESTRIAN AND FOLDING PLATFORM STACKER TRUCKS 24V, 1.0 - 1.6 TONNES



YOUR PERFECT SHORT SHUTTLE PARTNER

THIS RANGE OF STACKERS, INCORPORATING ALL THE LATEST TECHNOLOGY, IS DESIGNED FOR SHORT SHUTTLE APPLICATIONS AND STACKING UP TO 5.4 METRES. WITH A WIDE CHOICE OF PEDESTRIAN AND FOLD-DOWN PLATFORM MODELS, YOU WILL FIND A RELIABLE AND PRODUCTIVE WORKHORSE FOR ANY WAREHOUSE.



Energy-saving programmable drive options, robust construction and high resistance to water and dirt reduce running costs and boost productivity. Maintenance needs are minimised by an integrated drive and lift system, with fewer components, and quick access to all major truck parts.

Smooth and precise control characteristics and a comfortable operating position, with a user-friendly tiller arm and excellent visibility through the mast, ensure a satisfying user experience. Height-adjustable castor wheels* and high-strength masts help to maximise stability.

Models with a small fold-down platform are available at 1.0, 1.2*, 1.4 and 1.6 tonne capacities to take the legwork out of longer distances.

A new compact pedestrian stacker, the 1.2 tonne NSP12N2C, is now available. This powerful but space-saving model is ideal for filling store shelves, stacking, order picking and short internal transport work in, for example, warehouses, supermarkets and production areas.

*Excluding the NSP12N2C.

LOWER COST OF OWNERSHIP

- Latest AC technology keeps energy consumption and maintenance costs to bare minimum.
- Sturdy chassis construction and endurance-tested forks provide enhanced robustness and reliability even in the toughest conditions.
- Closed chassis and waterproof electrics resist moisture, dirt and corrosion - increasing uptime, cutting maintenance costs and prolonging truck life*.
- Easy access to critical truck components allows faster fault diagnosis and speedier maintenance, squeezing downtime still further.
- Integrated drive and lift system features fewer components than previous models, reducing scope for breakdown.
- Closed compartment with steel cover protects battery against impact, postponing costly battery replacement.
- Standard battery size allows interchangeability with other brands.

UNMATCHED PRODUCTIVITY

- AC motor results in very precise drive control, making life easier for truck operators.
- Standard LCD display* offers clear information on truck and battery condition.
- Ergonomic tiller arm helps keep operators fresh with comfortable, easy-to-use controls.
- Z-tiller arm / offset arm is available for loading in tight spaces such as lorries.
- Excellent drive and traction characteristics suit intensive work over short and medium distances.
- Distance of the fork support wheels from the rear frame has been optimised for increased stability.
- Advanced programmable controller lets users prioritise between faster performance and smoother handling with lower energy consumption, prolonging shift life.
- Tapered fork tips make for accurate and effortless pallet entry, speeding up handling cycles and preventing pallet or load damage.
- Truck can be driven with tiller arm in vertical position in ultra-low-speed 'tortoise' mode to maximise manoeuvrability in tight spaces.
- Narrower truck body makes handling operations in confined areas much easier.
- The compact NSP12N2C model is the narrowest and lightest stacker (at 660 mm and 775 kg including maximum battery) and like the NSP10-16N3/N31/N3S models, it has an offset tiller arm so the operator can walk alongside.
- N3R models feature fold-down driver platform that prevents operator fatigue over longer distances.
- N3R models' folding platform stays down when lowered, saving time when operators go to remount.
- NSP16N3 and N3R models fitted with the optional side stabilisers achieve greater lifting capacity at height.

- N31 initial lift models let operator raise mast and forks, increasing ground clearance to protect truck and load when working on ramps.
- N31 initial lift models can carry two pallets simultaneously using the initial lift on the support forks.
- N3S straddle models allow wider loads and bottom-boarded pallets to be handled with ease.

SAFETY AND ERGONOMICS

- Latest tiller arm design provides comfortable operating position.
- Large lift and lower levers allow easy, one-handed control, even with gloves.
- High-strength masts reduce load movement to a minimum.
- Slim mast profiles and careful hydraulic hose arrangements make for excellent forward visibility.
- Super-quiet oil-filled transmission helps keep noise levels low.
- Height-adjustable castor wheel eliminates play and raises load stability*.
- Speed regulated lifting and a proportional valve for lowering are standard on all models to provide precise, smooth, safe and productive handling.

*Excluding the NSP12N2C.



STANDARD EQUIPMENT AND OPTIONS

	NSP10N3(R)	NSP12N2C	NSP12N3(D)	NSP14N3(O)	NSP16N3(I)	NSP12N3(I)R	NSP14N3(I)R	NSP16N3(I)R	NSP16N3(S)	NSP16N3SR
GENERAL										
Multifunctional display, including hour meter	●	○	●	●	●	●	●	●	●	●
Micro-computer incl. hour meter and battery indicator	--	●	--	--	--	--	--	--	--	--
PIN code login 99 codes	--	●	--	--	--	--	--	--	--	--
PIN code login 4 codes	○	--	○	○	○	○	○	○	○	○
Offset tiller arm	--	●	--	--	--	--	--	--	○	--
Chill stone design, down to -10°C, with rust-protected axles	--	●	--	--	--	--	--	--	--	--
Speed regulated lifting and proportional valve for lowering, controlled by rocker switch on tiller head	●	●	●	●	●	●	●	●	●	●
Polyurethane drive wheel	●	●	●	●	●	●	●	●	●	●
Polyurethane drive wheel or rubber	--	●	--	--	--	--	--	--	--	--
Initial lift	--	--	(●)	(●)	(●)	(●)	(●)	(●)	--	--
Single load wheels polyurethane	●	●	●	--	--	--	--	--	--	--
Tandem load wheels polyurethane	○	○	○	●	●	●	●	●	●	●
Adjustable width between straddle load legs: 500mm - 1300mm	--	--	--	--	--	--	--	--	●	●
Sideways battery change (250Ah battery only)	--	--	○	○	○	○	○	○	○	○
Li-Ion batteries	○	○	○	○	○	○	○	○	○	○
ENVIRONMENT										
Cold stone design, 0°C to -35°C (0°C to -30°C; NSP12N2C)	○	○	○	○	○	○	○	○	○	○
DRIVE AND LIFT CONTROLS										
Tiller up drive	●	○	●	●	●	●	●	●	●	●
WHEEL OPTIONS										
Polyurethane traction and load wheels	●	●	●	●	●	●	●	●	●	●
Power friction traction wheel	○	○	○	○	○	○	○	○	○	○
Non-marking drive wheel	--	○	--	--	--	--	--	--	--	--
Anti-static drive wheel	--	○	--	--	--	--	--	--	--	--
OTHER OPTIONS										
Speed reduction 0.5km/h above 1000mm lift, duplex and triplex masts without free lift	--	--	○	○	○	○	○	○	○	○
Speed reduction 0.5km/h above free lift, duplex and triplex masts with free lift	--	--	○	○	○	○	○	○	○	○
Side Stabilisers (not on (I) model)	--	--	--	--	○	--	--	○	--	--
In-lift charger: 30A	○	○	○	○	○	○	○	○	○	○
Diselectric band	--	○	--	--	--	--	--	--	--	--
Key switch	●	●	●	●	●	●	●	●	●	●
Piano buzzer instead of standard horn	--	○	--	--	--	--	--	--	--	--
Special RAL colour	○	○	○	○	○	○	○	○	○	○
Load backrest	○	○	○	○	○	○	○	○	○	○
Accessory rack	○	--	○	○	○	○	○	○	○	○
Lift bracket, A4 size	○	--	○	○	○	○	○	○	○	○
Multi function display	--	○	--	--	--	--	--	--	--	--
Battery creep	--	○	--	--	--	--	--	--	--	--
Battery level audible warning	--	○	--	--	--	--	--	--	--	--
Service alarm	--	○	--	--	--	--	--	--	--	--
Automatic log off	--	○	--	--	--	--	--	--	--	--
Revert to low speed at log off	--	○	--	--	--	--	--	--	--	--

● Standard ○ Option

Characteristics		
1.1	Manufacturer	Cat Lift Trucks
1.2	Manufacturer's model designation	NSP120C
1.3	Power source	Battery
1.4	Operator type	Pedestrian
1.5	Load capacity	Q kg 1250
1.6	Load centre distance	c (mm) 600
1.8	Load wheel axle to fork face (forks lowered)	x (mm) 950
1.9	Wheelbase	y (mm) 1473
Weight		
2.1b	Truck weight without load, with maximum battery weight	kg 775
2.2	Axle loadings with nominal load & maximum battery weight, drive / load side	kg 875 / 1150
2.3	Axle loadings without load & with maximum battery weight, drive / load side	kg 575 / 200
Wheels, Drive Train		
3.1	Types: PT = Power Train; Vu1 = Vulcan, P = Polyurethane; N = Nylon; R = Rubber drive / load side	Vu1 / Vu1
3.2	Tyre dimensions, drive side	(mm) 230 x 70
3.3	Tyre dimensions, load side	(mm) 95 x 99
3.4	Castor wheel dimensions (diameter x width)	(mm) 140 x 60
3.5	Number of wheels, load / drive side (x = driven)	1 + 1x / 2
3.6	Track width (centre of tyre), drive side	(mm) 262
3.7	Track width (centre of tyre), load side	(mm) 255
Dimensions		
4.2b	Height	h1 (mm) 1400 / 1550
4.3	Free lift	h2 (mm) -
4.4	Lift height	h3 (mm) 1700 / 2000
4.5	Height with mast extended	h4 (mm) 2145 / 2445
4.6	Initial lift	h5 (mm) -
4.9	Height of tiller arm / steering console (min/max)	h14 (mm) 913 / 1308
4.15	Fork height, fully lowered	h13 (mm) 90
4.19	Overall length	l1 (mm) 1877
4.20	Length to fork face	l2 (mm) 677
4.21	Overall width	b1/b2 (mm) 660
4.22	Fork dimensions (thickness, width, length)	a / e / l (mm) 66 / 105 / 1200
4.24	Fork carriage width	b3 (mm) -
4.25	Outside width over forks (minimum / maximum)	b5 (mm) 540
4.26	Inner width of support legs	b4 (mm) -
4.32	Ground clearance at centre of wheelbase, forks lowered	m2 (mm) 25
4.32a	Working aisle width (Ast) with 1000 x 1200 mm pallets, load crosswise, platform up/down	Ast (mm) -
4.32d	Working aisle width (Ast3) with 1000 x 1200 mm pallets, load crosswise, platform up/down	Ast3 (mm) -
4.34a	Working aisle width (Ast) with 800 x 1200 mm pallets, load lengthwise	Ast (mm) 2507
4.34b	Working aisle width (Ast3) with 800 x 1200 mm pallets, load lengthwise	Ast3 (mm) 2285
4.34c	Working aisle width (Ast) with 800 x 1200 mm pallets, load lengthwise, platform up/down	Ast (mm) -
4.34d	Working aisle width (Ast3) with 800 x 1200 mm pallets, load lengthwise, platform up/down	Ast3 (mm) -
4.35	Turning radius	Wa (mm) 1825
Performance		
5.1	Travel speed, with / without load	km/h 5.7 / 6
5.2	Lifting speed, with / without load	m/s 0.10 / 0.20
5.3	Lowering speed, with / without load	m/s 0.11 / 0.12
5.7	Stability, with / without load	% 7 / 19
5.8	Maximum gradeability with / without load	% -
5.9	Acceleration time (10 metres) with / without load	s 7.00 / 6.76
5.10	Service brakes (mechanical / hydraulic / electric / pneumatic)	Electric
Electric motors		
6.1	Drive motor capacity (60 min, short duty)	kW 1.3
6.2	Lift motor output at 10% duty factor	kW 2.26
6.3	Battery to DIN	no
6.4	Battery voltage/capacity at 5 hour discharge	V/Ah 247 / 150 / 230
6.5	Battery weight	kg 140 / 215
Miscellaneous		
10.1	Type of drive control	Stepless
10.7	Level of noise at the ear level of the driver according to EN 12052:2001 and EN ISO 4871 in work LpA2	dB(A) 74.6 +/- 0.7
10.7.1	Load of noise at the ear level of the driver according to EN 12052:2001 and EN ISO 4871, drive with LpA2	dB(A) -
10.7.2	Whole body vibration (EN 12058:2002)	-
10.7.3	Hand-arm vibration (EN 13058:2002)	-

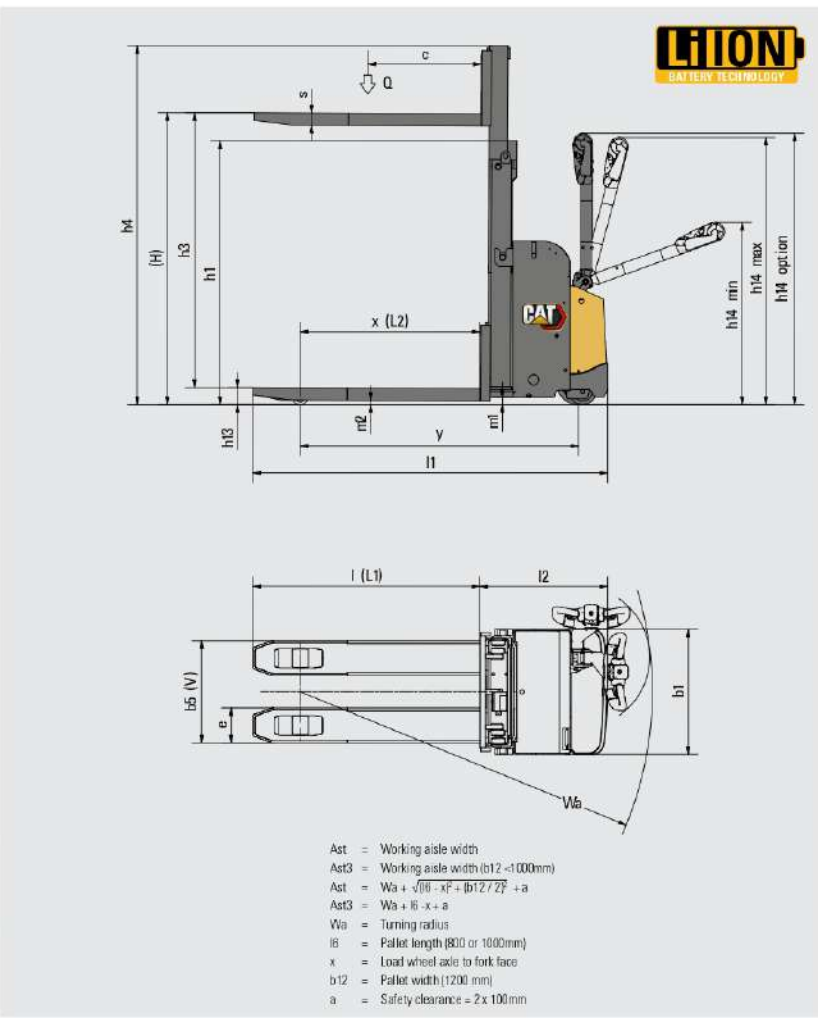

Characteristics			Car Lift Trucks	Car Lift Trucks	Car Lift Trucks	Car Lift Trucks
			NSP10N3	NSP12N3	NSP14N3	NSP16N3
			Battery	Battery	Battery	Battery
1.1	Manufacturer					
1.2	Manufacturer's model designation					
1.3	Power source					
1.4	Operator type		Pedestrian	Pedestrian	Pedestrian	Pedestrian
1.5	Load capacity	Q kg	1000	1200	1400	1600
1.6	Load centre distance	c (mm)	600	600	600	600
1.8	Load wheel axle to fork face (forks lowered)	x (mm)	290	290	290	290
1.9	Wheelbase	y (mm)	1215	1320	1330	1330
Weight						
2.1b	Truck weight without load, with maximum battery weight	kg	730	1020	1090	1090
2.2	Axle loadings with nominal load & maximum battery weight, drive / load side	kg	612 / 1128	810 / 1410	846 / 1580	870 / 1295
2.3	Axle loadings without load & with maximum battery weight, drive / load side	kg	534 / 995	720 / 205	730 / 295	730 / 295
Wheels, Drive Train						
3.1	Type: PT = Power Train, VuI = Vulkolan, P = Polyurethane, N = Nylon, R = Rubber drive / load axle		VuI / VuI	VuI / VuI	VuI / VuI	VuI / VuI
3.2	Type dimensions, drive axle	(mm)	230 x 70	230 x 70	230 x 70	230 x 70
3.3	Type dimensions, load axle	(mm)	85 x 90	85 x 90	85 x 75	85 x 75
3.4	Castor wheel dimensions (diameter x width)	(mm)	125 x 60	125 x 60	125 x 60	125 x 60
3.5	Number of wheels, load / drive axle (x = driven)		1 + 1x / 2	1 + 1x / 2	1 + 1x / 4	1 + 1x / 4
3.6	Track width (centre of tyre), drive axle	b10 (mm)	515	515	515	515
3.7	Track width (centre of tyre), load axle	b11 (mm)	385	385	385	385
Dimensions						
4.2b	Height	H1 (mm)	see tables	see tables	see tables	see tables
4.3	Free lift	H2 (mm)	see tables	see tables	see tables	see tables
4.4	Lift height	H3 (mm)	see tables	see tables	see tables	see tables
4.5	Height with mast extended	H4 (mm)	see tables	see tables	see tables	see tables
4.6	Initial lift	H5 (mm)	-	-	-	-
4.9	Height of tiller arm / steering console (min/max)		865 / 1440	865 / 1420	865 / 1420	865 / 1420
4.15	Fork height, fully lowered	h13 (mm)	90	90	90	90
4.19	Overall length	l1 (mm)	1825	1900 ¹	1900	1900
4.20	Length to fork face	l2 (mm)	685	750 ²	750	750
4.21	Overall width	b1/b2 (mm)	600	600	600	600
4.22	Fork dimensions (thickness, width, length)	a / e / l (mm)	56 / 106 / 1190	56 / 106 / 1190	56 / 106 / 1190	56 / 106 / 1190
4.24	Fork carriage width	b3 (mm)	750	750	750	750
4.25	Outside width over forks (minimum / maximum)	b5 (mm)	570	570	570	570
4.26	Inner width of support legs	b4 (mm)	-	-	-	-
4.32	Ground clearance at centre of wheelbase, forks lowered	m4 (mm)	20	20	20	20
4.32a	Working aisle width (Ast) with 1000 x 1200 mm pallets, load crosswise, platform up/down	Ast (mm)	2300	2445	2445	2445
4.32b	Working aisle width (Ast3) with 1000 x 1200 mm pallets, load crosswise, platform up/down	Ast3 (mm)	-	-	-	-
4.32c	Working aisle width (Ast) with 800 x 1200 mm pallets, load lengthwise	Ast (mm)	-	-	-	-
4.32d	Working aisle width (Ast3) with 800 x 1200 mm pallets, load lengthwise	Ast3 (mm)	-	-	-	-
4.34a	Working aisle width (Ast) with 800 x 1200 mm pallets, load lengthwise, platform up/down	Ast (mm)	2220	2314	2314	2314
4.34b	Working aisle width (Ast3) with 800 x 1200 mm pallets, load lengthwise, platform up/down	Ast3 (mm)	-	-	-	-
4.35	Turning radius	Wa (mm)	1458	1572	1572	1572
Performance						
5.1	Travel speed, with / without load	km/h	6.0 / 6.0	6.0 / 6.0	6.0 / 6.0	6.0 / 6.0
5.2	Lifting speed, with / without load	m/s	0.15 / 0.30	0.16 / 0.33	0.14 / 0.33	0.15 / 0.32
5.3	Lowering speed, with / without load	m/s	0.29 / 0.32	0.48 / 0.35	0.45 / 0.35	0.48 / 0.34
5.7	Stability, with / without load	%	-	-	-	-
5.8	Maximum gradability with / without load	%	8 / 15	8 / 15	8 / 15	8 / 15
5.9	Acceleration time (10 series) with / without load	s	-	-	-	-
5.10	Service brakes (mechanical / hydraulic / electric / pneumatic)		Electric	Electric	Electric	Electric
Electric motors						
6.1	Drive motor capacity 60 min, short duty	kW	1.0	1.0	1.0	1.0
6.2	Lift motor output at 15% duty factor	kW	2.2	2.2	2.2	3.2
6.3	Battery to DIN		-	-	-	-
6.4	Battery voltage/capacity at 5 hour discharge	V/Ah	24 / 150	24 / 150	24 / 250	24 / 250 / 375
6.5	Battery weight	kg	150	210	210	210
6.6a	Energy consumption according to EN 60336	Wh/h	0.46	0.76	0.77	0.77
Miscellaneous						
8.1	Type of drive control		Stepless	Stepless	Stepless	Stepless
10.7	Level of noise at the ear level of the driver according to EN 12052:2001 and EN ISO 4871, in work (pA2)	(dB(A))	65	64	-	-
10.7.1	Level of noise at the ear level of the driver according to EN 12052:2001 and EN ISO 4871, drive (pA2)	(dB(A))	-	-	-	-
10.7.2	Whole-body vibration (EN 13059:2002)		-	-	-	-
10.7.3	Hand-arm vibration (EN 13059:2002)		< 2.5	< 2.5	< 2.5	< 2.5

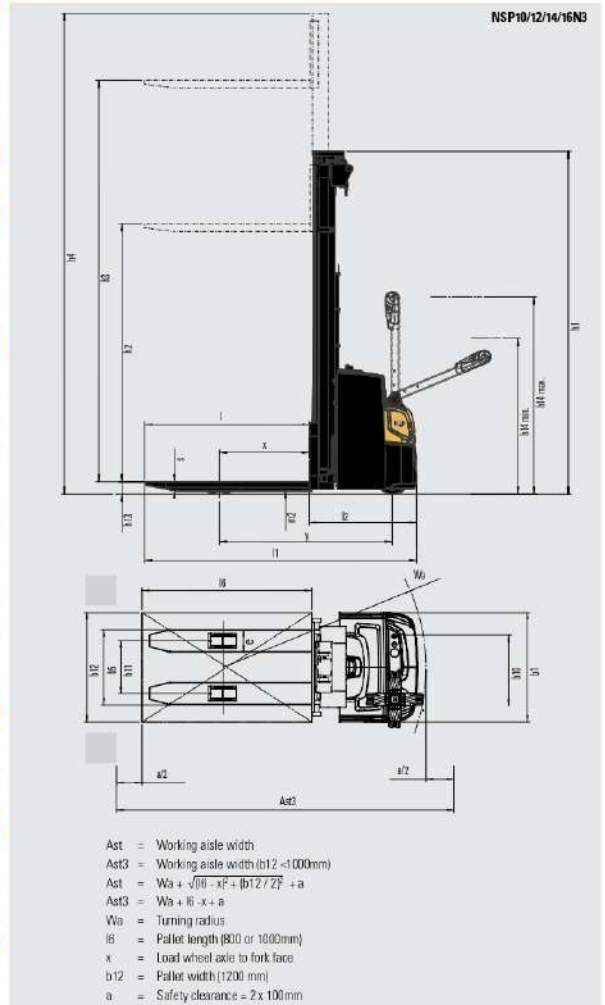

9: 64mm with 150 Ah battery

Characteristics		Car Lift Trucks NSP10NR	Car Lift Trucks NSP12NR	Car Lift Trucks NSP14NR	Car Lift Trucks NSP16NR
1.1	Manufacturer				
1.2	Manufacturer's model designation				
1.3	Power source	Battery	Battery	Battery	Battery
1.4	Operator type				
1.5	Load capacity	0 kg	1200	1400	1600
1.6	Load centre distance	600 (mm)	600	600	600
1.8	Load wheel axle to fork face (forks lowered)	x (mm)	750	750	750
1.9	Wheelbase	y (mm)	1215	1320	1320
Weight					
2.1b	Truck weight without load, with maximum battery weight	kg	860	1100	1100
2.2	Axle loadings with nominal load & maximum battery weight, drive / load side	kg	715 / 1155	840 / 1400	860 / 1705
2.3	Axle loadings without load & with maximum battery weight, drive / load side	kg	640 / 220	860 / 260	740 / 295
Wheels, Drive Train					
3.1	Type: PT = Power Train, VuI = Vulkan, P = Polyurethane, N = Nylon, R = Rubber drive / load axle				
3.2	Type dimensions, drive axle	(mm)	VuI / VuI	VuI / VuI	VuI / VuI
3.3	Type dimensions, load axle	(mm)	230 x 70	230 x 70	230 x 70
3.4	Castor wheel dimensions (diameter x width)	(mm)	85 x 90	85 x 90	85 x 75
3.5	Number of wheels, load / drive axle (x = driven)		125 x 60	125 x 60	125 x 60
3.6	Track width (centre of tyre), drive axle	b10 (mm)	1 + 1 x / 2	1 + 1 x / 2	1 + 1 x / 4
3.7	Track width (centre of tyre), load axle	b11 (mm)	515	515	515
Dimensions					
4.2b	Height	M (mm)	see tables	see tables	see tables
4.3	Free lift	N2 (mm)	see tables	see tables	see tables
4.4	Lift height	N3 (mm)	see tables	see tables	see tables
4.5	Height with mast extended	N4 (mm)	see tables	see tables	see tables
4.6	Initial lift	N5 (mm)	-	-	-
4.8	Height of tiller arm / steering console (min/max)	N14 (mm)	1155 / 1550	1155 / 1550	1155 / 1550
4.15	Fork height, fully lowered	N13 (mm)	90	90	90
4.19	Overall length	L (mm)	1925 / 2435	2040 / 2500	2040 / 2500
4.20	Length to fork face	L2 (mm)	806 / 1265	870 / 1350	870 / 1350
4.21	Overall width	b1/b2 (mm)	600	600	600
4.22	Fork dimensions (thickness, width, length)	a / e / l (mm)	56 / 106 / 1190	56 / 106 / 1150	56 / 106 / 1190
4.24	Fork carriage width	b3 (mm)	750	750	750
4.25	Outside width over forks (minimum / maximum)	b5 (mm)	570	570	570
4.26	Inner width of support legs	b4 (mm)	-	-	-
4.32	Ground clearance at centre of wheelbase, forks lowered	m2 (mm)	20	20	20
4.33a	Working aisle width (Ast) with 1000 x 1200 mm pallets, load crosswise, platform up/down	Ast (mm)	2420 / 2900	2500 / 3030	2550 / 3060
4.33b	Working aisle width (Ast3) with 1000 x 1200 mm pallets, load crosswise, platform up/down	Ast3 (mm)			
4.34a	Working aisle width (Ast) with 800 x 1200 mm pallets, load lengthwise	Ast (mm)			
4.34b	Working aisle width (Ast) with 800 x 1200 mm pallets, load lengthwise, platform up/down	Ast (mm)	2350 / 2830	2620 / 2980	2650 / 2980
4.34c	Working aisle width (Ast3) with 800 x 1200 mm pallets, load lengthwise, platform up/down	Ast3 (mm)			
4.35	Turning radius	Wa (mm)	1578 / 2558	1692 / 2172	1692 / 2170
Performance					
5.1	Travel speed, with / without load	km/h	6.0 / 6.0	6.0 / 6.0	6.0 / 6.0
5.2	Lifting speed, with / without load	m/s	0.15 / 0.30	0.16 / 0.33	0.14 / 0.33
5.3	Lowering speed, with / without load	m/s	0.29 / 0.32	0.46 / 0.35	0.45 / 0.35
5.7	Stability, with / without load	%			
5.8	Maximum gradability with / without load	%	8 / 15	8 / 15	8 / 15
5.9	Acceleration time (10 series) with / without load	s			
5.10	Service brakes (mechanical / hydraulic / electric / pneumatic)		Electric	Electric	Electric
Electric motors					
6.1	Drive motor capacity 60 min, short duty	kW	1.0	1.0	1.0
6.2	Lift motor output at 10% duty factor	kW	2.2	2.2	3.2
6.3	Battery to DIN				
6.4	Battery voltage/capacity at 5 hour discharge	V/Ah	24 / 150 - 250	24 / 150 - 250	24 / 250 - 375
6.5	Battery weight	kg	150	210	210
6.8a	Energy consumption according to EN 60336	Wh/h	0.75	0.77	0.78
Miscellaneous					
10.1	Type of drive control		Stepless	Stepless	Stepless
10.2	Level of noise at the ear level of the driver according to EN 12103:2001 and EN ISO 4871, in work LpA2	(dB(A))			
10.2.1	Level of noise at the ear level of the driver according to EN 12103:2001 and EN ISO 4871, drive/tilt side LpA2	(dB(A))			
10.2.2	Whole-body vibration (EN 13109:2002)		0.8	0.8	0.8
10.2.3	Hand-arm vibration (EN 13109:2002)		< 2.5	< 2.5	< 2.5

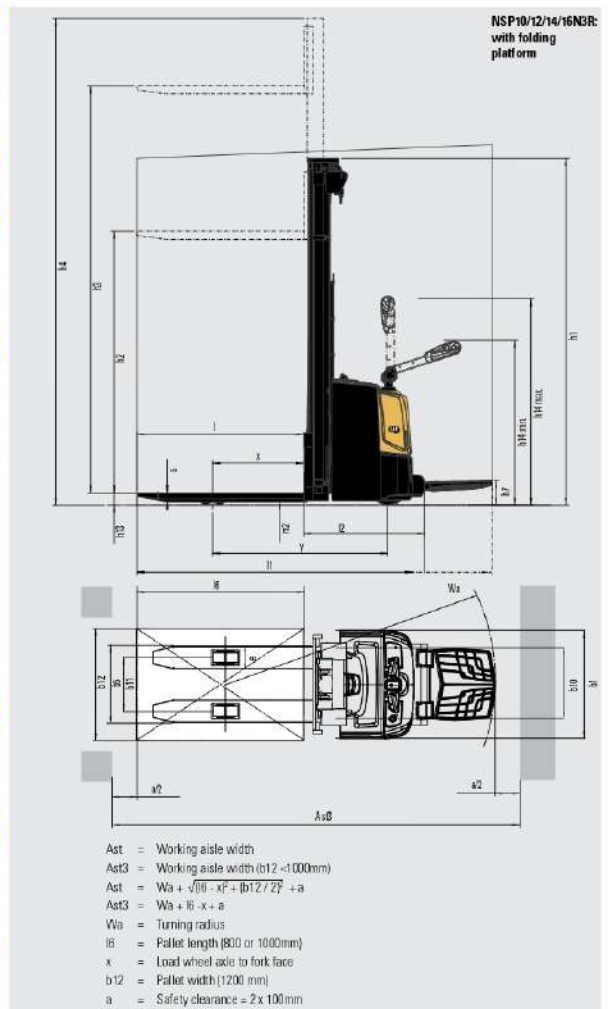

Characteristics		Car Lift Trucks NSP12N3IR Battery	Car Lift Trucks NSP14N3IR Battery	Car Lift Trucks NSP16N3IR Battery
1.1	Manufacturer			
1.2	Manufacturer's model designation			
1.3	Power source	Battery	Battery	Battery
1.4	Operator type	Footrest / Stand on	Footrest / Stand on	Footrest / Stand on
1.5	Load capacity	1200	1400	1600
1.6	Load centre distance	600	600	600
1.8	Load wheel axle to fork face (forks lowered)	925	925	925
1.9	Wheelbase	1610	1610	1610
Weight				
2.1b	Truck weight without load, with maximum battery weight	1175	1175	1175
2.2	Axle loadings with nominal load & maximum battery weight, drive / load side	1030 / 1360	1115 / 1460	1200 / 1675
2.3	Axle loadings without load & with maximum battery weight, drive / load side	840 / 325	840 / 325	840 / 325
Wheels, Drive Train				
3.1	Type: PT = Power Train, VuI = Vulkolan, P = Polyurethane, N = Nylon, R = Rubber drive / load axle	VuI / VuI	VuI / VuI	VuI / VuI
3.2	Tyre dimensions, drive side	230 x 70	230 x 70	230 x 70
3.3	Tyre dimensions, load side	85 x 90	85 x 75	85 x 75
3.4	Castor wheel dimensions (diameter x width)	125 x 60	125 x 60	125 x 60
3.5	Number of wheels, load / drive axle (x = driven)	1 + 1 x / 2	1 + 1 x / 4	1 + 1 x / 4
3.6	Track width (centre of tyre), drive side	515	515	515
3.7	Track width (centre of tyre), load side	385	385	385
Dimensions				
4.2b	Height	h1 (mm)	see tables	see tables
4.3	Free lift	h2 (mm)	see tables	see tables
4.4	Lift height	h3 (mm)	see tables	see tables
4.5	Height with mast extended	h4 (mm)	see tables	see tables
4.6	Initial lift	h5 (mm)	200	200
4.9	Height of tiller arm / steering console (min/max)	h14 (mm)	1155 / 1550	1155 / 1550
4.15	Fork height, fully lowered	h13 (mm)	90	90
4.19	Overall length	l (mm)	2125 / 2605	2125 / 2605
4.20	Length to fork face	l2 (mm)	975 / 1455	975 / 1455
4.21	Overall width	b1/b2 (mm)	600	600
4.22	Fork dimensions (thickness, width, length)	a / e / l (mm)	56 / 106 / 1190	56 / 106 / 1190
4.24	Fork carriage width	b3 (mm)	750	750
4.25	Outside width over forks (minimum / maximum)	b5 (mm)	570	570
4.26	Inner width of support legs	b4 (mm)	-	-
4.32	Ground clearance at centre of wheelbase, forks lowered	m2 (mm)	20	20
4.32a	Working aisle width (Ast) with 1000 x 1200 mm pallets, load crosswise, platform up/down	Ast (mm)	2743 / 3223	2743 / 3223
4.32b	Working aisle width (Ast3) with 1000 x 1200 mm pallets, load crosswise, platform up/down	Ast3 (mm)	-	-
4.34a	Working aisle width (Ast) with 800 x 1200 mm pallets, load lengthwise	Ast (mm)	-	-
4.34b	Working aisle width (Ast3) with 800 x 1200 mm pallets, load lengthwise	Ast3 (mm)	-	-
4.34c	Working aisle width (Ast) with 800 x 1200 mm pallets, load lengthwise, platform up/down	Ast (mm)	2657 / 3137	2657 / 3137
4.34d	Working aisle width (Ast3) with 800 x 1200 mm pallets, load lengthwise, platform up/down	Ast3 (mm)	-	-
4.35	Turning radius	Wa (mm)	1972 / 2452	1972 / 2452
Performance				
5.1	Travel speed, with / without load	km/h	6.0 / 6.0	6.0 / 6.0
5.2	Lifting speed, with / without load	m/s	0.16 / 0.33	0.14 / 0.33
5.3	Lowering speed, with / without load	m/s	0.46 / 0.35	0.45 / 0.35
5.7	Stability, with / without load	%	-	-
5.8	Maximum gradability with / without load	%	8 / 15	8 / 15
5.9	Acceleration time (10 series) with / without load	s	-	-
5.10	Service brakes (mechanical / hydraulic / electric / pneumatic)		Electric	Electric
Electric motors				
6.1	Drive motor capacity 60 min, short duty	kW	1.0	1.0
6.2	Lift motor output at 10% duty factor	kW	2.2	2.2
6.3	Battery to DIN		-	-
6.4	Battery voltage/capacity at 5 hour discharge	V/Ah	24 / 150 - 250	24 / 150 - 375
6.5	Battery weight	kg	210	210
6.6a	Energy consumption according to EN 61366	Wh/h	0.77	0.78
Miscellaneous				
10.1	Type of drive control		Stepless	Stepless
10.7	Level of noise at the ear level of the driver according to EN 12103:2001 and EN ISO 4871, in work LpA2	dB(A)	-	-
10.7.1	Level of noise at the ear level of the driver according to EN 12103:2001 and EN ISO 4871, drive/tilt/idle LpA2	dB(A)	-	-
10.7.2	Whole-body vibration (EN 13059:2002)		0.8	0.8
10.7.3	Hand-arm vibration (EN 13059:2002)		< 2.5	< 2.5

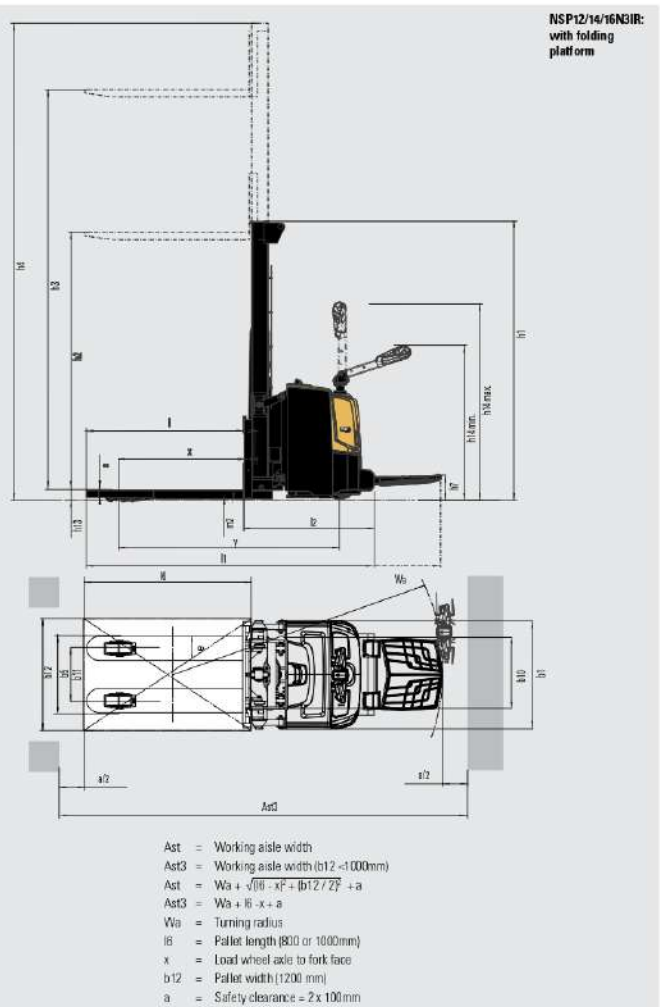

NSP12/14/16N3IR
with folding
platform

Characteristics			Col Lift Trucks	Col Lift Trucks
			NSP16N3S	NSP16N3SR
			Battery	Battery
			Pedestrian	Pedestrian/Station
1.1	Manufacturer		1600	1600
1.2	Manufacturer's model designation		600	600
1.3	Power source		750	750
1.4	Operator type		1395	1395
1.5	Load capacity	Q kg		
1.6	Load centre distance	c (mm)		
1.8	Load wheel axle to fork face (forks lowered)	x (mm)		
1.9	Wheelbase	y (mm)		
Weight				
2.1b	Truck weight without load, with maximum battery weight	kg	1888	1440
2.2	Axle loadings with nominal load & maximum battery weight, drive / load side	kg	1045 / 1870	1215 / 1995
2.3	Axle loadings without load & with maximum battery weight, drive / load side	kg	892 / 206	1020 / 420
Wheels, Drive Train				
3.1	Type: PT = Power Train, VuI = Vulkan, P = Polyurethane, N = Nylon, R = Rubber drive / load side		VuI / VuI	VuI / VuI
3.2	Type dimensions, drive side	(mm)	230 x 70	230 x 70
3.3	Type dimensions, load side	(mm)	85 x 75	85 x 75
3.4	Castor wheel dimensions (diameter x width)	(mm)	125 x 60	125 x 60
3.5	Number of wheels, load / drive side (x = driven)		1 + 1 x / 4	1 + 1 x / 4
3.6	Track width (centre of tyre), drive side	b10 (mm)	515	515
3.7	Track width (centre of tyre), load side	b11 (mm)	1025 / 1425	1025 / 1425
Dimensions				
4.2b	Height	H1 (mm)	see tables	see tables
4.3	Free lift	H2 (mm)	see tables	see tables
4.4	Lift height	H3 (mm)	see tables	see tables
4.5	Height with mast extended	H4 (mm)	see tables	see tables
4.6	Initial lift	H5 (mm)	-	-
4.9	Height of tiller arm / steering console (min/max)	H14 (mm)	865 / 1420	1155 / 1550
4.15	Fork height, fully lowered	H13 (mm)	85	85
4.19	Overall length	L (mm)	1965	2065 / 2565
4.20	Length to fork face	L2 (mm)	815	935 / 1415
4.21	Overall width	b1/b2 (mm)	800 / 1140 / 1575	800 / 1140 / 1575
4.22	Fork dimensions (thickness, width, length)	s / e / l (mm)	40 / 100 / 1190	40 / 100 / 1150
4.24	Fork carriage width	b3 (mm)	990	990
4.25	Outside width over forks (minimum / maximum)	b5 (mm)	260-300	260-300
4.26	Interaxle width of support legs	b4 (mm)	900-1300	900-1300
4.32	Ground clearance at centre of wheelbase, forks lowered	m2 (mm)	20	20
4.32a	Working aisle width (Aa1) with 1000 x 1200 mm pallets, load crosswise, platform up/down	Aa1 (mm)	2580	2690 / 3170
4.32b	Working aisle width (Aa2) with 1000 x 1200 mm pallets, load crosswise, platform up/down	Aa2 (mm)		
4.32c	Working aisle width (Aa3) with 800 x 1200 mm pallets, load lengthwise, platform up/down	Aa3 (mm)		
4.32d	Working aisle width (Aa4) with 800 x 1200 mm pallets, load lengthwise, platform up/down	Aa4 (mm)		
4.32e	Working aisle width (Aa5) with 800 x 1200 mm pallets, load lengthwise, platform up/down	Aa5 (mm)	2580	2690 / 3170
4.35	Turning radius	Wa (mm)	1627	1757 / 2227
Performance				
5.1	Travel speed, with / without load	km/h	6.0 / 6.0	6.0 / 6.0
5.2	Lifting speed, with / without load	m/s	0.15 / 0.32	0.15 / 0.32
5.3	Lowering speed, with / without load	m/s	0.43 / 0.34	0.5 / 0.34
5.7	Stability, with / without load	%		
5.8	Maximum gradeability with / without load	%	8 / 15	8 / 15
5.9	Acceleration time (10 series) with / without load	s		
5.10	Service brakes (mechanical / hydraulic / electric / pneumatic)		Electric	Electric
Electric motors				
6.1	Drive motor capacity (60 min, short duty)	kW	1.0	1.0
6.2	Lift motor output at 10% duty factor	kW	3.2	3.2
6.3	Battery to DIN			
6.4	Battery voltage/capacity at 5-hour discharge	V / Ah	24 / 250 - 375	24 / 250 - 375
6.5	Battery weight	kg	210	210
6.6a	Energy consumption according to EN16736	Wh/h	0.77	0.78
Miscellaneous				
10.1	Type of drive control		Stepless	Stepless
10.7	Level of noise at the ear level of the driver according to EN 12 052:2001 and EN ISO 4871, in work IpA2	dB(A)		
10.7.1	Level of noise at the ear level of the driver according to EN 12 052:2001 and EN ISO 4871, drive/forward IpA2	dB(A)		
10.7.2	Whole-body vibration (EN 13 059:2002)		-	0.8
10.7.3	Hand-arm vibration (EN 13 059:2002)		< 2.5	< 2.5

$Aa1$ = Working aisle width
 $Aa3$ = Working aisle width (b12 < 1000mm)
 $Aa5$ = $Wa + \sqrt{(B-x)^2 + (b12/2)^2} + a$
 $Aa3$ = $Wa + B - x + a$
 Wa = Turning radius
 B = Pallet length (800 or 1000mm)
 x = Load wheel axle to fork face
 $b12$ = Pallet width (1200 mm)
 a = Safety clearance = 2 x 100mm

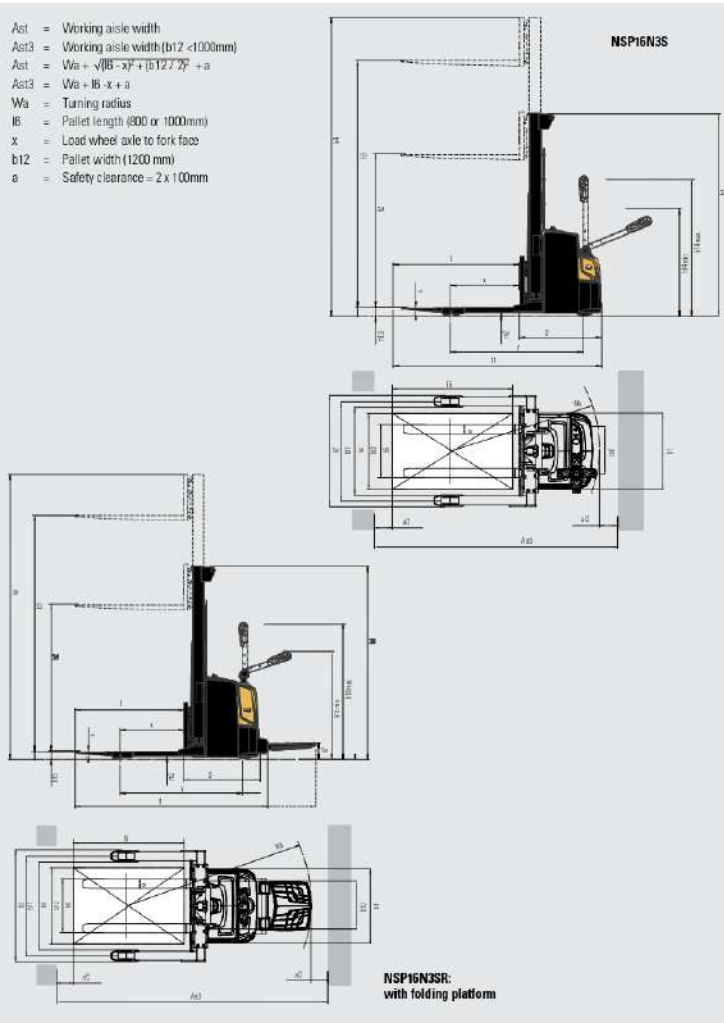

NSP16N3SR
with folding platform

NSP12N2C			
Mast Type	h3+h13	h1*	h2+h13
	mm	mm	mm
Duplex:	1790	1400	NA
Without Free Lift	2090	1550	NA

*h1 closed mast height includes polycarbonate finger protection. Mast height excl. finger protection is 1343mm / 1493mm

NSP10N310N3R				
Mast type	h3+h13	h1*	h4	h2+h13
	mm	mm	mm	mm
S	1500	1380	1980	1500
D	2500	1775	3000	195
	2900	1975	3400	195
	3300	2175	3800	195

NSP12/14/16N3 / NSP12/14/16N3R				
Mast Type	h3+h13	h1*	h4	h2+h13
	mm	mm	mm	mm
S	1500	1350	1950	1500
DS	2500	1835	3000	200
	2900	2035	3400	200
	3300	2235	3800	200
	3600	2335	4100	200
	4300	2735	4900	200
DEV	2500	1775	2940	1355
	2900	1975	3340	1555
	3300	2235	3800	1755
	3600	2335	4100	1905
	4300	2735	4900	2255
TR	4100	1935	4640	-
	4300	2020	4840	-
	4700	2150	5240	-
	5400*	2385	5940	-
	TREV	4100	1955	4640
4300		2020	4840	1540
4700		2153	5240	1673
5400*		2385	5940	1905

NSP12/14/16N31 / NSP12/14/16N31R				
Mast type	h3+h13	h1*	h4	h2+h13
	mm	mm	mm	mm
S	1500	2055	2055	1505
DS	2500	1940	3105	200
	2900	2140	3505	200
	3300	2340	3905	200
	3600	2490	4205	200
	4300	2840	4905	200
	4300	2940	4905	2260
TR	4100	2060	4745	-
	4300	2125	4945	-
	4700	2260	5345	-
	5400*	2490	6045	-
TREV	4100	2060	4745	1480
	4300	2125	4945	1545
	4700	2260	5345	1673
	5400*	2490	6045	1910

NSP16N3S / NSP16N3SR				
Mast type	h3+h13	h1*	h4	h2+h13
	mm	mm	mm	mm
S	1500	2030	2030	1500
DS	2500	1915	3090	195
	2900	2115	3490	195
	3300	2315	3890	195
	3600	2465	4190	195
	4300	2815	4890	195
DEV	2500	1915	3090	1355
	2900	2115	3490	1555
	3300	2315	3890	1755
	3600	2465	4190	1905
	4300	2815	4890	2255
TR	4100	2095	4720	-
	4300	2100	4820	-
	4700	2233	5320	-
	5400	2465	6020	-
TREV	4100	2035	4720	1475
	4300	2100	4820	1540
	4700	2233	5320	1753
	5400	2465	6020	1905

Mast Performance and Capacity

- * = only NSP14-16N3R & NSP14-16N31R
- S = Simplex
- D = Duplex standard
- DS = Duplex with clear view mast
- DEV = Duplex with full free lift
- TR = Triplex with clear view mast
- TREV = Triplex with full free lift
- h3-h13 = Lifting height
- h1 = Lowered mast height
- h4 = Raised mast height
- h2-h13 = Free lift



LI-ION BATTERIES

TIME TO SWITCH?



Lithium-ion (Li-ion) battery technology is available in the Cat® electric counterbalance and warehouse truck ranges. While lead-acid batteries remain a popular choice for our customers, and still have much to offer, they present various challenges which Li-ion can overcome.

Perhaps the most noticeable change when switching to Li-ion is the use of opportunity charging. Instead of exchanging batteries between shifts, you can simply plug into a fast charger during short breaks and keep the same battery going 24/7. This, together with other efficiency, environmental and safety benefits, makes Li-ion a very appealing alternative.

 LONGER LIFE	 HIGHER EFFICIENCY	 LONGER RUNTIME	 CONSISTENT PERFORMANCE
 FASTER CHARGING	 NO BATTERY CHANGING	 NO DAILY MAINTENANCE	 INBUILT PROTECTION

Cat Li-ion advantages over lead-acid

Li-ion is an investment which should be viewed against ongoing savings on energy, equipment, labour and downtime.

- **Longer life** – 3 to 4 times lead-acid lifespan – reduces overall battery investment
- **Higher efficiency** – energy losses during charging and discharging are up to 30% lower, so electricity consumption is reduced
- **Longer runtime** – thanks to more efficient battery performance and use of opportunity charges, which can be given at any time without damaging the battery or shortening its lifespan
- **Consistently high performance** – with a more constant voltage curve – maintains greater truck productivity, even toward the end of a shift
- **Faster charging** – enables full charge in as little as 1 hour with the fastest chargers
- **No battery changing** – fast opportunity charges – 15 minutes for several hours of extra runtime – enable continuous operation with just one battery and minimise the need to buy, store and maintain spares
- **No daily maintenance** – the battery stays on board the truck for charging and there is no need for water top-ups or electrolyte checks
- **No gas** – or acid spills – avoids the space, equipment and running costs of a battery room and ventilation system
- **Inbuilt protection** – intelligent battery management system (BMS) automatically prevents excessive discharge, charge, voltage and temperature, as well as virtually eliminating misuse

Batteries and chargers with different capacities are available. Your dealer will identify the best combination for your needs. You should also ask your dealer about optional 5-year warranties, subject to annual check-ups, which give extra peace of mind.

info@catlifttruck.com | www.catlifttruck.com

WFS2218/09/22 © 2022 MLE B.V. (registration no. 33274439). All rights reserved. CAT, CATERPILLAR, LET'S DO THE WORK, their respective logos, "Caterpillar Corporate Yellow", the "Power Edge" and Cat "Modern Hex" trade dress as well as corporate and product identity used herein, are trademarks of Caterpillar and may not be used without permission.

NOTE: Performance specifications may vary depending on standard manufacturing tolerances, vehicle condition, type of tyres, floor or surface conditions, application, or operating environment. Trucks may be shown with non-standard options. Specific performance requirements and locally available configurations should be discussed with your Cat Lift Trucks Dealer. Cat Lift Trucks follows a policy of continual product improvement. For this reason, some materials, options and specifications could change without notice.

